

CABLE BONDING JUMPER:

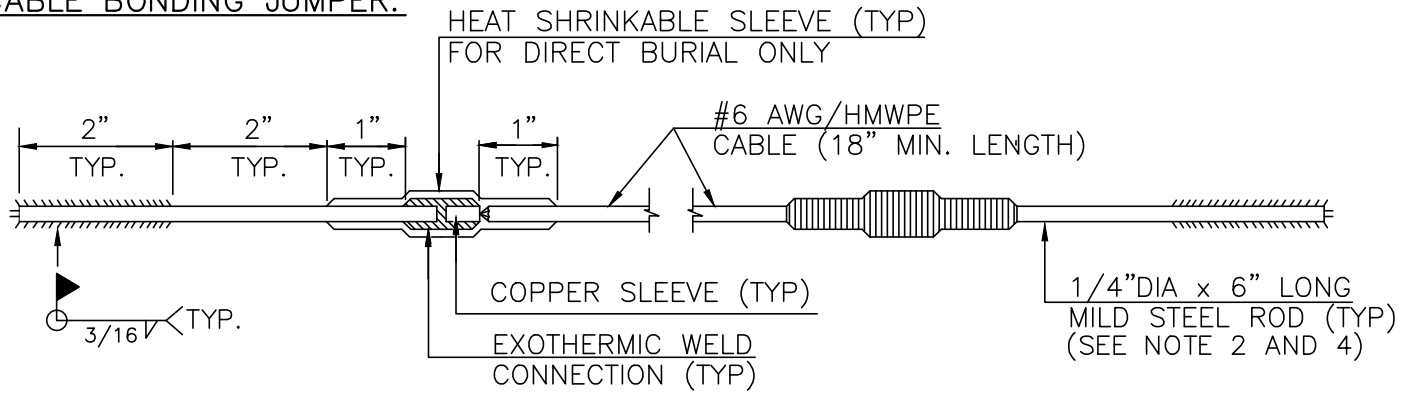

BELL - SPIGOT ENDS:

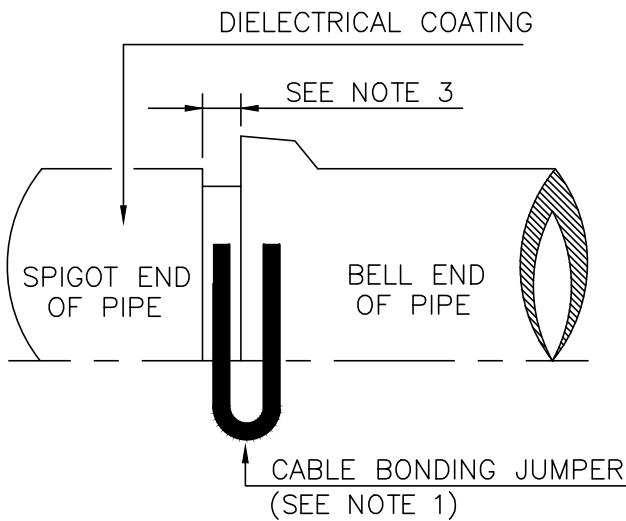

RESTRAINED JOINTS:

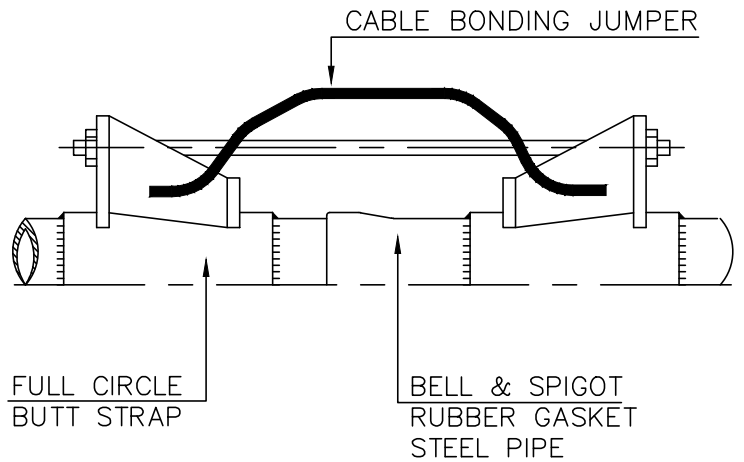

**FLEXIBLE FITTINGS
AND
FLANGED ENDS:**

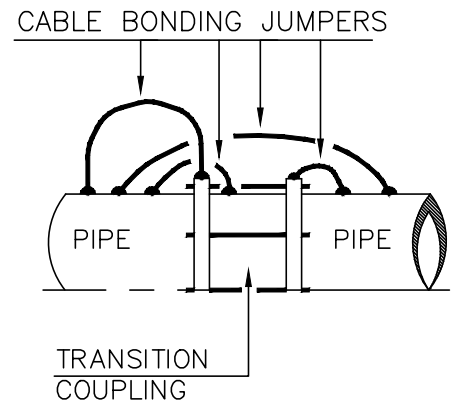
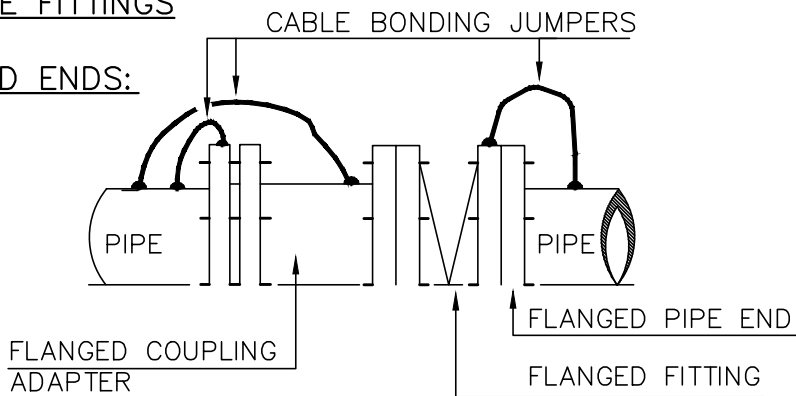

NOTES:

- 1) ONE CABLE BONDING JUMPER REQ'D PER JOINT
- 2) BEND ROD TO MATCH PIPE RADIUS.
- 3) PROVIDE SUFFICIENT DISTANCE BETWEEN WELDED ROD AND CONNECTION BELL TO ALLOW FOR MAXIMUM PIPE DEFLECTION.
- 4) WELD TO BARE STEEL.
- 5) EXPOSED STEEL WILL BE COATED WITH PRIMER AND WRAPPED WITH COAL TAR TAPE. #6 AWG/HMWPE CABLE SHOULD BE LEFT UNWRAPPED AND FREE TO MOVE.



**CABLE BONDING JUMPER
INSTALLATION**

FOR BELL & SPIGOT STEEL PIPE & FITTINGS

APPROVED	DATE	REV	STD NO
	5\10\02	1	11

THIS STANDARD REPLACES NMWD STD-A-28